

REMOTE CONTROL DECODER

DESCRIPTION

The SC5272 is a remote control decoder paired with SC5262 utilizing CMOS technology. It has a maximum of 12-bits of tri-state address pins providing up to 531,441(or 3^{12}) address codes; thereby, drastically reducing any code collision and unauthorized code scanning possibilities.

FEATURES

- * Low power consumption and very high noise immunity
- * Up to 12 tri-state code address pins or 6 data pins
- * Wide operating voltage range($V_{cc}=3V \sim 15V$)
- * Single resistor oscillator
- * Latch or Momentary output type

APPLICATION

- * Home/automation security system
- * Remote control toys or for industrial use
- * Remote control fan
- * Garage door controller

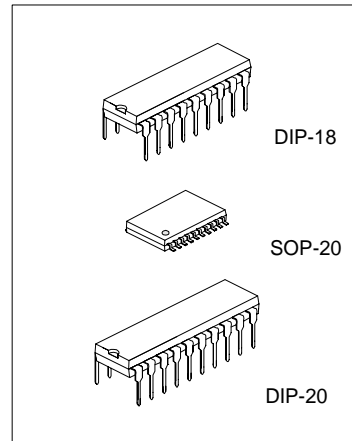

ORDERING INFORMATION

SC5272X-XX

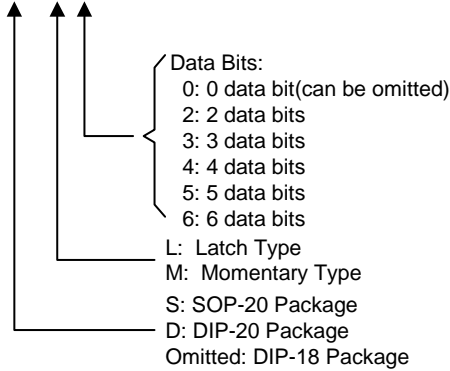

PIN CONFIGURATION

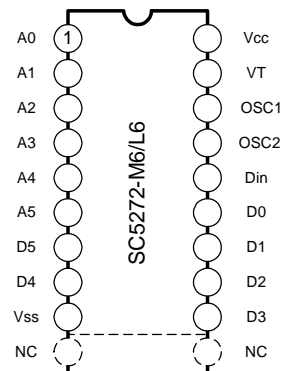
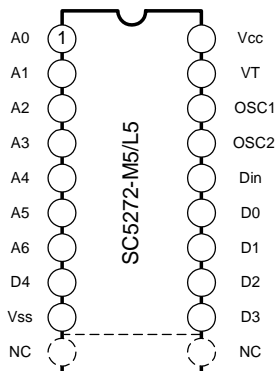
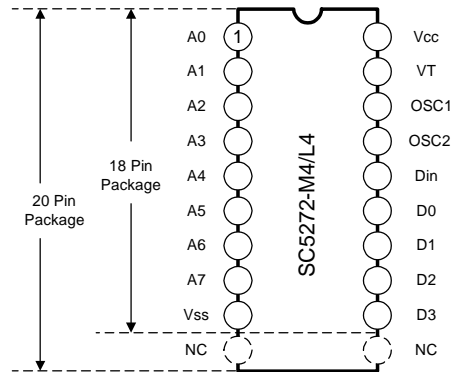
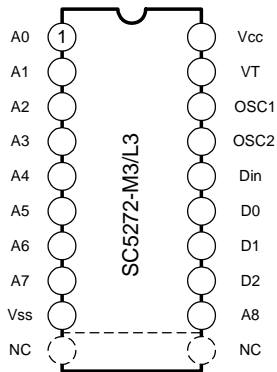
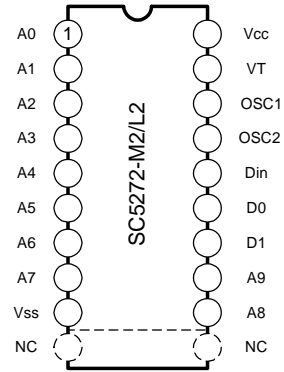
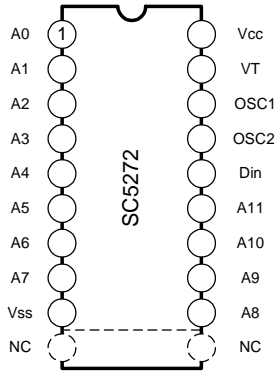

BLOCK DIAGRAM

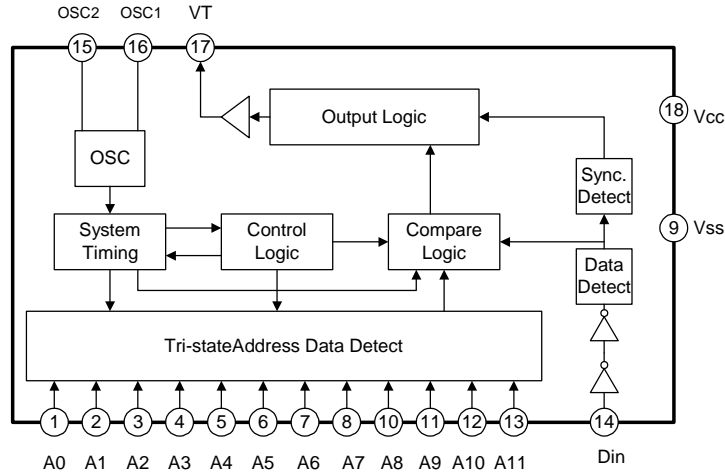

The Pin configurations are for DIP-18 package and are also some different with the SC5272 suffix (please refer to the Pin Configuration)

ABSOLUTE MAXIMUM RATINGS($T_a=25^{\circ}\text{C}$)

Characteristics	Symbol	Value	Unit
Supply Voltage	Vcc	-0.3 ~ 16.0	V
Input Voltage	Vi	-0.3 ~ Vcc+0.3	V
Output Voltage	Vo	-0.3 ~ Vcc+0.3	V
Maximum Power Dissipation(Vcc=12V)	Pa	300	mW
Operating Temperature	Topr	-20 ~ +70	°C
Storage Temperature	Tstg	-40 ~ +125	°C

ELECTRICAL CHARACTERISTICS

($T_a=25^{\circ}\text{C}$, Vcc=12V, unless otherwise specified)

Characteristics	Symbol	Test Condition	Min.	Typ.	Max.	Unit
Supply Voltage	Vcc		3		15	V
Supply Current	Icc	Vcc=12V, OSC stops A0~ A11 Open		0.02	0.3	μA
Dout Output driving Current	IOH	Vcc=5V, VOH=3V	-3			mA
		Vcc=8V, VOH=4V	-6			mA
		Vcc=12V, VOH=6V	-10			mA
Dout Output sinking Current	IOL	Vcc=5V, VOL=3V	2			mA
		Vcc=8V, VOL=4V	5			mA
		Vcc=12V, VOL=6V	9			mA
Input High Voltage	VIH		0.7Vcc		Vcc	V
Input Low Voltage	VIL		0		0.3Vcc	V

HANGZHOU SILAN MICROELECTRONICS CO.,LTD.

Rev: 1.0 2004.08.03

PIN DESCRIPTION

Pin No.		Pin Name	Description
18 PIN	20 PIN		
1~6	1~6	A0~A5	Code Address pins No. 0~5. These six tri-state pins are detected by SC5272 to determine the encoded waveform bit 0 ~bit 5. Each pin can be set to "0", "1", "f"(floating).
7~8 10~13	7~8 12~15	A6/D5~A11/D0	Code Address pins No.6~11/data pins No.5~0. These six pins are used higher address input bits or data output pins depending on the versions of SC5272 used. When these pins are used as address pins, they are tri-state input pins and can be set to "0", "1", "f". When they are used as output pins, they are driven to Vcc if (1) the address decoded from the waveform that was received matches the address setting at address input pins, and (2) the corresponding data bits received is a "1" bits. Otherwise, they are driven to Vss.
14	16	DIN	Data Input Pin. The encode waveform received is serially fed to SC5272 at this pin.
15	17	OSC1	Oscillator pin 1
16	18	OSC2	Oscillator pin 2
17	19	VT	Valid Transmission. Active high signal. VT in high state signifies that SC5272 receives valid transmission waveform.
18	20	Vcc	Positive Power Supply
9	9	Vss	Negative Power Supply
--	10~11	NC	No Connection

FUNCTIONAL DESCRIPTION

The SC5272 decodes the waveform received and fed into the Din pin. The waveform is decoded into code word that contains the address, data and Sync bits. The decoded address bits are compared with the address set at the address input pins. If both addresses match for 2 consecutive code words, SC5272 drives:

- The data output pins whose corresponding data bits is then decoded to be a "1" bit
- The VT output --to high voltage (high state).

1. RF OPERATION

Code Bits

A code bit is the basic component of the encoded waveform, and can be classified as either an AD(Address/Data) Bit or a SYNC(Synchronous) Bit.

An AD bit can be designated as bit "0", "1" or "f" if it is in low, high or floating state respectively. One bit waveform consists of two pulse cycles. Each pulse cycle has 16 oscillating time periods. For further details, please refer to the diagram below:

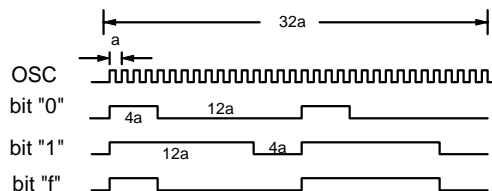

Where: a = oscillating clock period . Bit "f" is only available for address bits.

The Synchronous bit waveform is 4 bits long with 1/8 bit width pulse. Please refer to the diagram below:

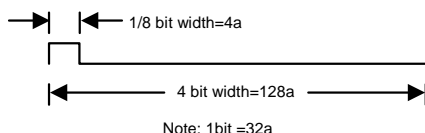

Code word

A group of Code Bits is called a Code Word. A Code Word consists of 12 AD bits followed by one Sync. Bit. The 12 AD bits are interpreted as either address or data bits depending on the SC5272 version used. Please refer to the diagram below:

A0	A1	A2	A3	A4	A5	A6	A7	A8	A9	A10	A11	SYNC
----	----	----	----	----	----	----	----	----	----	-----	-----	------

Single Resistor Oscillator

The Build-in oscillator circuitry of SC5272 allows a precision oscillator to be constructed by connecting an external resistor between OSC1 and OSC2 pins. For SC5272 to decode correctly the received waveform, the oscillator frequency of SC5272 must be 2.5 ~8 times that of transmitting SC5262. It is a good practice to center the SC5272 oscillator frequency in the window to gain best window margin at both sides. The typical oscillator frequency with various resistor values for both SC5262 and SC5272 are shown below:

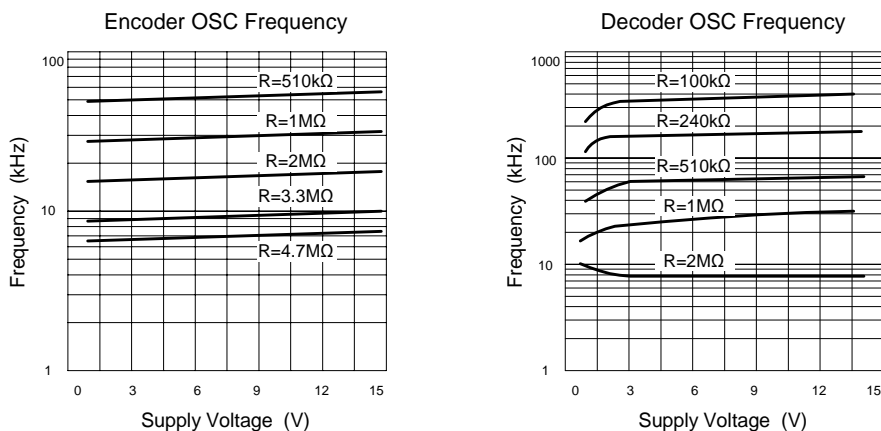

Suggested Oscillator resistor values are shown below:

SC5262	SC5272
4.7MΩ	820kΩ
3.3MΩ	680kΩ
1.2MΩ	200kΩ

2. IR OPERATION

In the IR Type of operation, the functions are similar to the above descriptions except that the output waveform carried by SC5262-IR has a frequency of 38kHz. Details are as follows.

Code Bits

The Code Bits are further modulated with a 38kHz carrier frequency and can be "0", "1" or "f" bit. Their waveform are shown below:

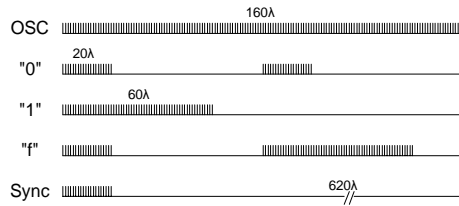

Note: $\lambda=2$ clock lengths

Code Word

A Code Word is made up of code bits and the format is the same as that of the RF Code Word.

Code Frame

Likewise, a Code Frame is made up of Code Words and the format is the same as that of RF type of operation.

Oscillator

The SC5262-IR is specially designed for infrared remote control applications and its output waveform carries 38kHz frequency. To get the 38kHz carrier frequency at the data output, the oscillator frequency must be 76kHz. A $440k\Omega$ resistor connected between OSC1 and OSC2 pins of SC5262-IR is recommended. Moreover, for a matching decoder frequency, $1M\Omega$ resistor connected between the OSC1 and OSC2 pins of SC5272 is also recommended.

3. VALID TRANSMISSION

When the SC5272 receives a transmission code word, it initially checks whether this is a valid transmission. For a transmission to be valid, (1) it must be a complete code word, and (2) the address bits must match the address setting at the address pins. After two consecutive valid transmission, SC5272 (1) drives the data pins according to the data bits received, and (2) rise VT to high voltage (high state).

The timings are shown in the following diagram.

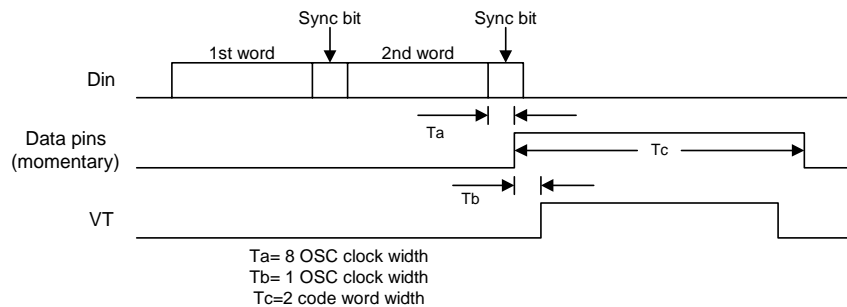

4.LATCH OR MOMENTARY DATA OUTPUT TYPE

The SC5272 uses either the latch or momentary data output type depending on the SC5272 version used. The latch type SC5272-LX activates the data out during transmission and this data is sustained in the memory until another data is inputted or entered. A momentary type(SC5272-MX) on the other hand, activates the data out only during transmission. In the momentary type, the data does not remain in the memory after the transmission is completed. Please refer to the diagram below:

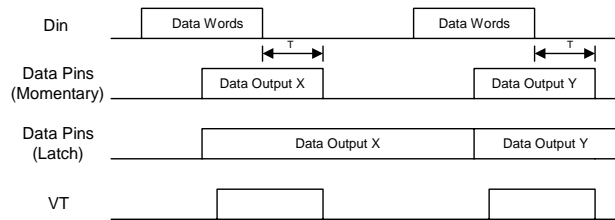

OPERATION FLOW CHART

Decoder Without Data Output Pin

1. When the power is turned on, the SC5272 activates the Stand-By Mode.
2. It then search for signals, If there is no signal received, it remains in the Stand-By Mode; otherwise, the address bits received are compared with the address configuration of the pins.
3. The VT goes high signifying the validation of transmission only when there are two continuous frames that contain matched address bit; otherwise, VT will not be activated and the Stand-By Mode remains active.
4. Then , the address bits are again checked. Two continuous mismatches of the address bits would disable the VT and make the Stand-By Mode active; otherwise, the address bits are continuous checked.

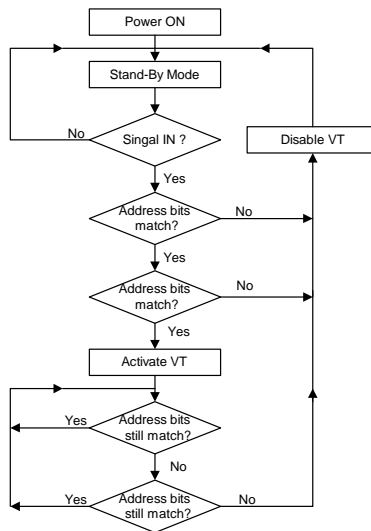

Decoder Without Data Output Pin

Decoder With Data Output Pins

1. When the power is turned on ,the SC5272 activates the Stand-By Mode.
2. It then searches for signal. If there is no signal received , it remains in the Stand-By Mode; otherwise, the address bits are compared with the address configuration of the pins.
3. Whenever the address bits in frame match with that of the address configuration of the pin, the data bits are stored into memory. Also, when this IC finds two continuous and identical data having the same address bits, the data outputs is activated and the VT is enabled. The VT is disabled when there are two continuous mismatched addresses. For the momentary type, the data output is reset; while for the latch type, the data output is sustained.

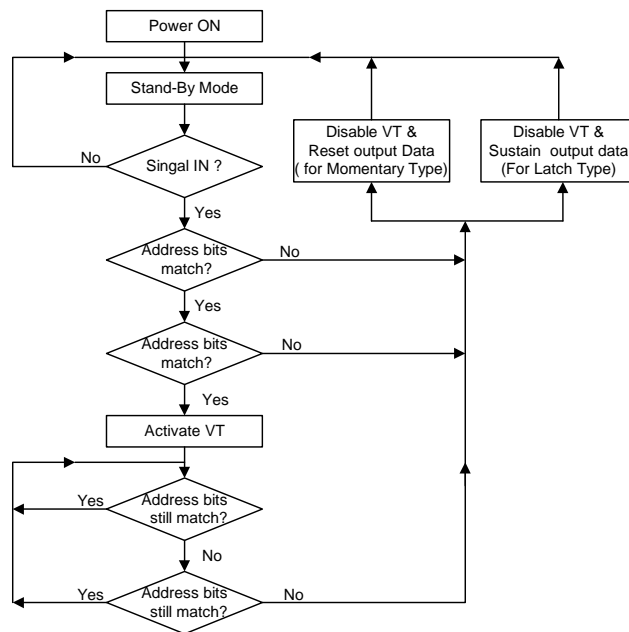

Decoder With Data Output Pins

TYPICAL APPLICATION CIRCUIT

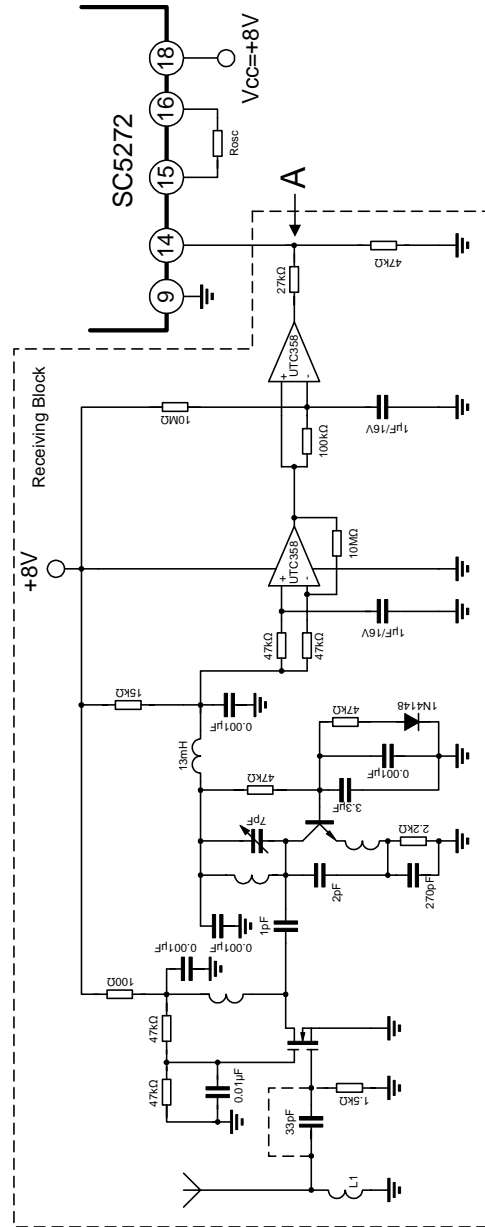

SC5272(No Data) RF Application Circuit

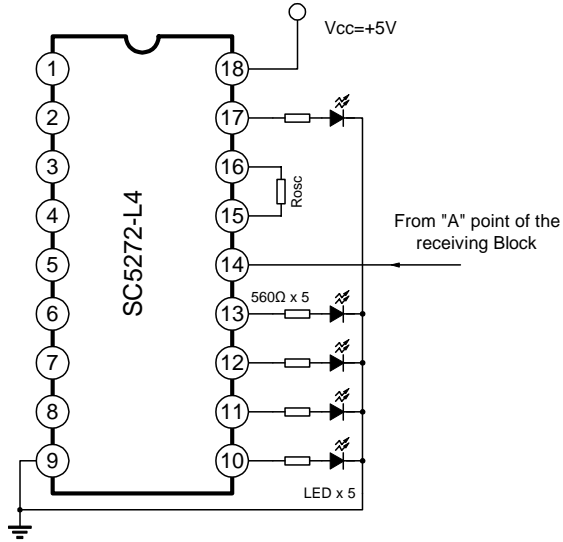

SC5272-L4(4 Data) RF Application Circuit

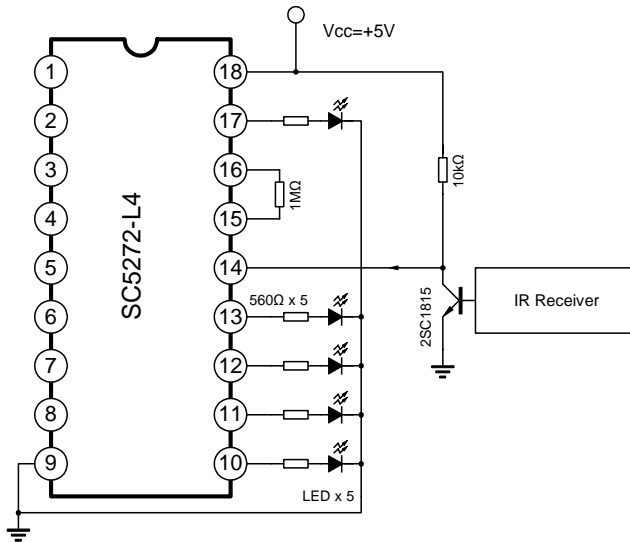

SC5272-L4(4 Data) IR Application Circuit

PACKAGE OUTLINE

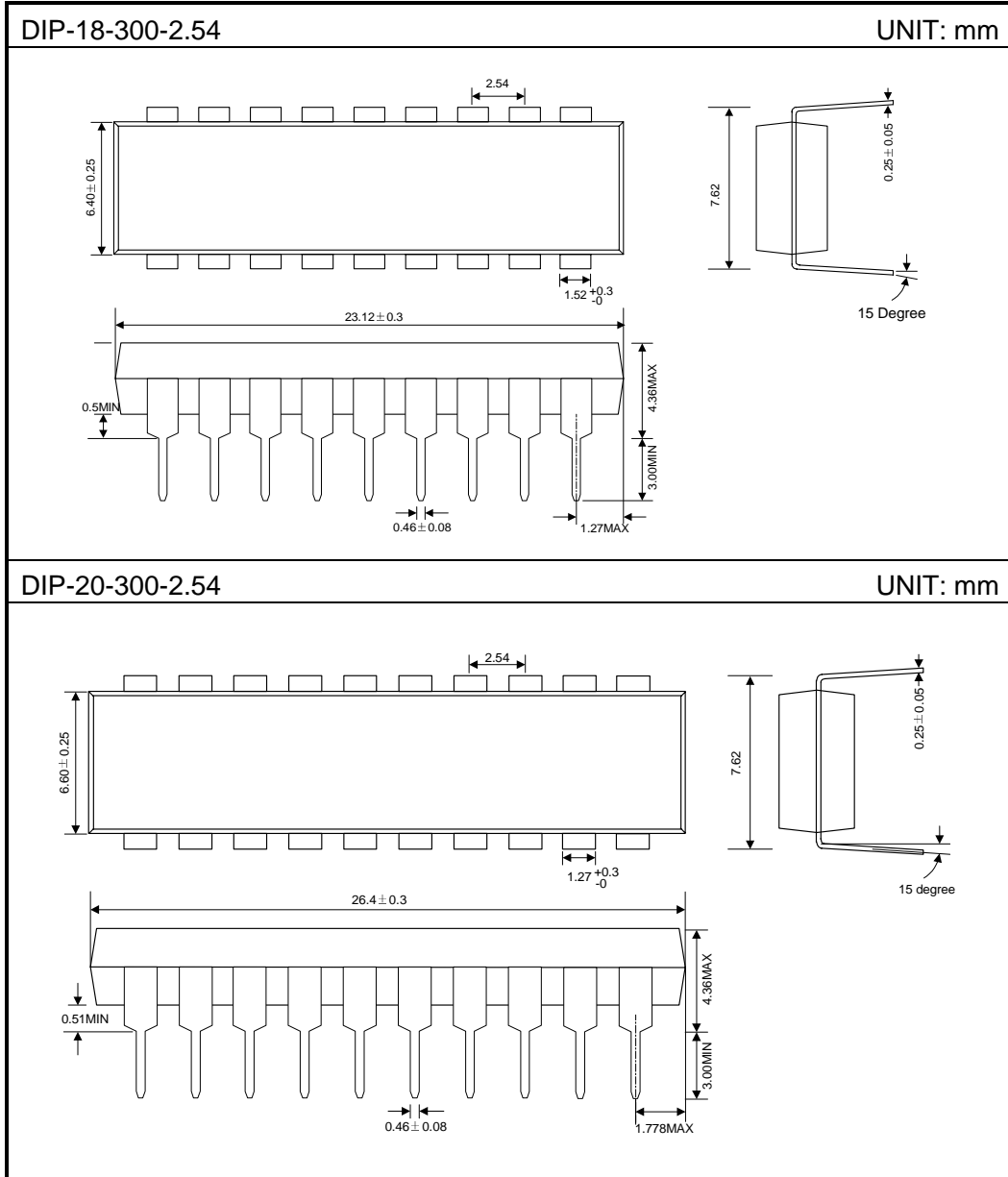

PACKAGE OUTLINE

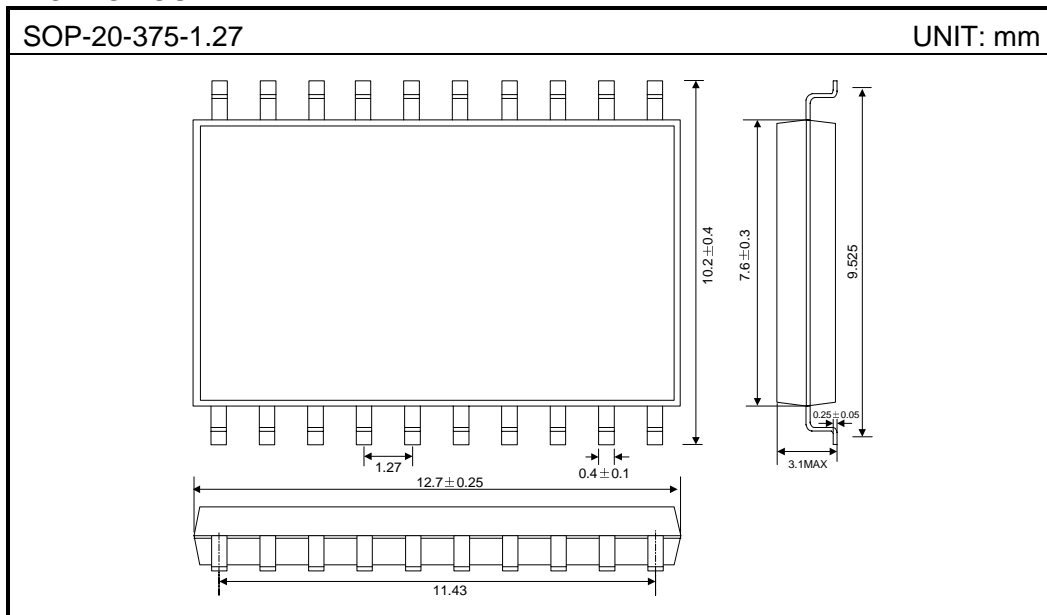

HANDLING MOS DEVICES:

Electrostatic charges can exist in many things. All of our MOS devices are internally protected against electrostatic discharge but they can be damaged if the following precautions are not taken:

- Persons at a work bench should be earthed via a wrist strap.
- Equipment cases should be earthed.
- All tools used during assembly, including soldering tools and solder baths, must be earthed.
- MOS devices should be packed for dispatch in antistatic/conductive containers.